

DIGITAL CAPACITIVE ACCELEROMETER USB INTERFACE

DynaLabs

DYN-300000-US

Capacitive accelerometers are based on proven micro-electro-mechanical systems (MEMS) technology.



These capacitive accelerometers are reliable, long-term stable, and precise. MEMS technology facilitates the precise measurement of both static (DC) and continuous accelerations, allowing for the calculation of the velocity and displacement of moving objects. Sensor is designed with three digital interfaces (USB, RS232, CAN) and can detect dynamic (AC) accelerations with amplitudes ranging from $\pm 2g$ to $\pm 40g$. It has a speed of up to 4000 samples per second and a resolution close to $4 \mu g$ in three axes. Users can choose the appropriate sensor based on their needs. The power supply voltage is flexible, ranging from 5 to 16 VDC. The triaxial accelerometers allow quick and easy mounting.



Features

- Triaxial
- Resolution: $4 \mu g$
- Sample Rate: 125, 500, 1000 SPS
- Measurement Range: $\pm 2g$, $\pm 4g$, $\pm 8g$ for 8g
- Measurement Range: $\pm 10g$, $\pm 20g$, $\pm 40g$ for 40g
- Frequency Range ($\pm 5\%$): DC to 200 Hz
- Frequency Range ($\pm 10\%$): DC to 240 Hz
- Frequency Range (3dB): DC to 450 Hz
- Temperature Measurement



Applications

- General Industrial Test & Measurement
- Condition Monitoring
- Robotics and Automation
- Tilt sensing
- Seismic imaging



Software Features

- Display and Record: X, Y, Z Acceleration, Temperature
- Analyze: FFT, Downsample, Average
- Calibration: Linear Equation
- Export: .CSV, .MAT, .TXT and .PNG

Full-scale Acceleration	(g)	± 2	± 4	± 8	± 10	± 20	± 40
Scale Factor	(μg /LSB)	3,906	7,812	15,625	19,5	39	78
Sensitivity (Change / °C)	(%/°C)	± 0.01	± 0.01	± 0.01	± 0.01	± 0.01	± 0.01
0 g Offset	(mg)	± 25	± 25	± 25	± 125	± 125	± 125
Noise	($\mu g/\sqrt{Hz}$)	25	25	25	75	85	90
Non-Linearity	(%)	0,1	0,8	1,6	0,1	0,5	1,3
Resolution (1 LSB)	(μg)	4	8	16	20	40	80



DYNALABS MUHENDISLIK LTD STI

Ostim OSB Mah. 100 Yil Bulvarı Ostim
No:55B/11 Yenimahalle 06374 Ankara
TURKEY

Phone: +90 312 386 21 89

Mail: dynalabs@dynalabs.com.tr

Web: www.dynalabs.com.tr

DynaLabs

DIGITAL CAPACITIVE ACCELEROMETER

USB INTERFACE

DYN-300000-US

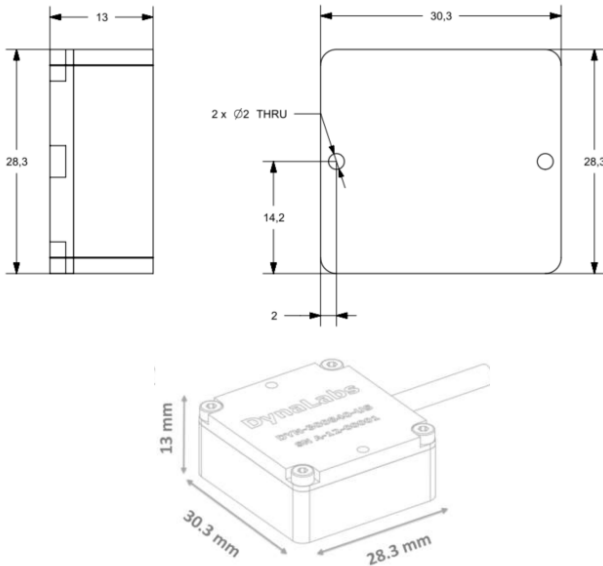

OPTIONS:

- Customize Range
- Customize Frequency
- Customize Cable Length (5m standard cable)
- Customize Aluminum or Steel

Sample per second (SPS)	Low-Pass Filter (Hz)
125	31,25
500	125
1000	250

Marking:

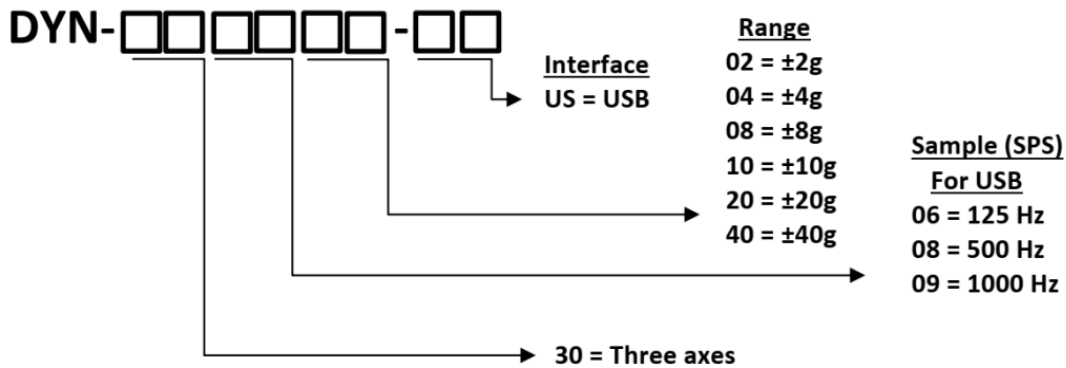

Example: DYN-300840-US: Triaxial, 500 SPS, ±40 g, Capacitive Accelerometer with USB Interface.

Operating Voltage	Operating Power/Current	Operating Temperature	Shock Limit
5V - 16 V	1W/62.5 mA	-40 °C to + 85 °C	5000 g

Protection Level	Connector at Sensor (open ended)	Mounting	Housing Material	Weight (without cable)
IP 68	Pin 1 Red +5V Pin 2 White D- Pin 3 Green D+ Pin 4 Black GND	Adhesive or screw mount	Anodized Aluminum	80 g



DYNALABS MUHENDISLIK LTD STI

Ostim OSB Mah. 100 Yil Bulvarı Ostim
No:55B/11 Yenimahalle 06374 Ankara
TURKEY

Phone: +90 312 386 21 89

Mail: dynalabs@dynalabs.com.tr

Web: www.dynalabs.com.tr