

ANALOG CAPACITIVE ACCELEROMETER WITH CONNECTOR

DynaLabs

DYN-C-3000-LN-C

Capacitive accelerometers are based on proven micro-electro-mechanical systems (MEMS) technology.



These capacitive accelerometers are reliable and long-term stable. They have DC response. The advantage of these sensors is their outstanding temperature stability, their high frequency response and their lightweight. These sensors have reliable aluminum housing with IP68 protection class. Additionally, their connectorized design ensures easy integration. Dynalabs 3000LN series triaxial accelerometers provide an outstanding noise performance from 9 to 680 $\mu\text{g}/\sqrt{\text{Hz}}$. These accelerometers provide a wide frequency range ($\pm 5\%$) from 700 Hz to 2,900 Hz.



Features

- Accurate DC measurement
- Voltage Output
- High frequency response
- High shock protection
- Low noise - high resolution
- Differential output signal
- Gas damping



Application Areas

- Structural monitoring and testing
- Aerospace vibration testing
- Automotive ride quality & comfort
- Railway engineering
- GVT and flutter testing

		3002LN	3005LN	3010LN	3030LN	3050LN	3100LN	3200LN
Full-scale Acceleration	(g)	± 2	± 5	± 10	± 30	± 50	± 100	± 200
Sensitivity	(mV/g)	1,350	540	270	90	54	27	13.5
Frequency range ($\pm 5\%$)	(Hz)	700	1,150	2,000	2,300	2,700	2,900	2,500
Non-linearity (full scale)	(%)	0.15	0.15	0.15	0.15	0.15	0.15	0.15
Noise (in band)	($\mu\text{g}/\sqrt{\text{Hz}}$)	9	21	40	100	180	340	680
Bias temperature	(mg/ $^{\circ}\text{C}$)	± 0.2	± 0.5	± 1	± 3	± 5	± 10	± 20
Shock survivability	(g)	± 3000 g pk	± 3000 g pk	± 3000 g pk	± 3000 g pk	± 3000 g pk	± 3000 g pk	± 3000 g pk



DYNALABS MUHENDISLIK LTD STI

Ostim OSB Mah. 100 Yil Bulvarı Ostim
No:55B/11 Yenimahalle 06374 Ankara
TURKEY

Phone: +90 312 386 21 89

Mail: dynalabs@dynalabs.com.tr

Web: www.dynalabs.com.tr

DynaLabs

ANALOG CAPACITIVE ACCELEROMETER WITH CONNECTOR

DYN-C-3000-LN-C

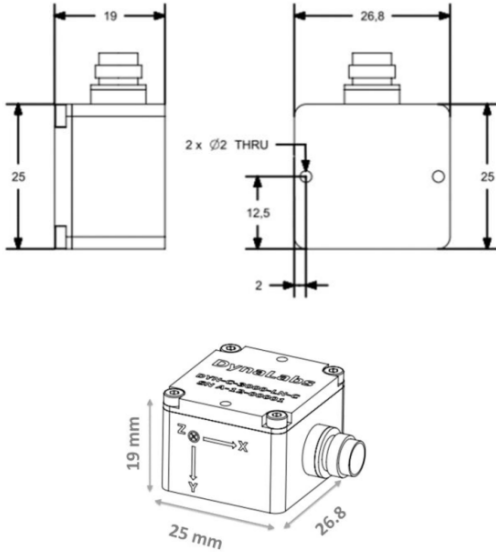

OPTIONS:

- Custom Cable Length (5m standard cable)
- Custom Housing Material
- Base plate

Standard length of the integrated cable is 5 meters. But, based on request customized cable lengths are possible (10m, 15m, 20m)

CABLE CODE/PIN CONFIGURATION:

- Red : V + Supply voltage
- Black : Ground GND
- X-Axis : Yellow : Signal(+) Positive, analog output voltage signal for differential mode
: Purple : Signal(-) Negative, analog output voltage signal for differential mode
- Y-Axis : Blue : Signal(+) Positive, analog output voltage signal for differential mode
: Green : Signal(-) Negative, analog output voltage signal for differential mode
- Z-Axis : White : Signal(+) Positive, analog output voltage signal for differential mode
: Orange : Signal(-) Negative, analog output voltage signal for differential mode

Cable: 8x #28 AWG Conductors PFA Insulated, Braided Shield, TPE Jacket

Protection Level	Operating Voltage	Operating Temperature	Weight (without cable)
IP 68	6 V - 40 V	-40 °C to +100 °C	28 g (aluminum) 55 g (steel)
Housing Material	Connector (Optional)	Mounting	Base plate (Optional)
Aluminum or Steel	D-Sub 9 or 15 pin, Lemo, Binder	Adhesive or screw mount	Aluminum or Steel



DYNALABS MUHENDISLIK LTD STI

Ostim OSB Mah. 100 Yil Bulvarı Ostim
No:55B/11 Yenimahalle 06374 Ankara
TURKEY

Phone: +90 312 386 21 89

Mail: dynalabs@dynalabs.com.tr

Web: www.dynalabs.com.tr